

Technical requirement

- 1, pattern draft is 1-2° of main beams ,cover ,grids, frame side.
- 2, pattern draft is 5-10° of assistive beams ,grid holes ,outside.
- 3, pattern draft is 15° of surface patterns ,mark, logo.
- 4, casting radius which aren' t been marked is R1-R3.

General Dimension Tolerance	General Weight Tolerance
According To ISO 8062-CT10	Tolerance(%)
	±5%

MATERIAL	GJS500-7	WEIGHT	26.5kg	CLASS	EN124-2 D400	SCALE		MARK:	
						SIZE	500x500x80	CERTIFICATE NO. / PRODUCT CODE	ICIM
 <b>OBLIKUJEMO VODNE CESTE</b>						ITEM CODE	L-GSGEN-450FL		
								EDITION	0



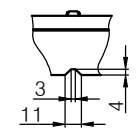
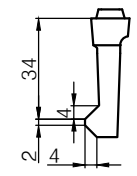
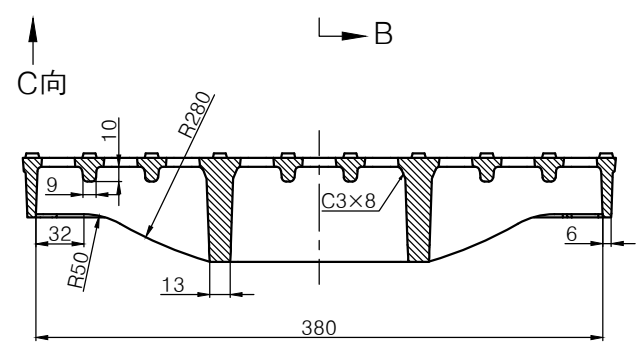
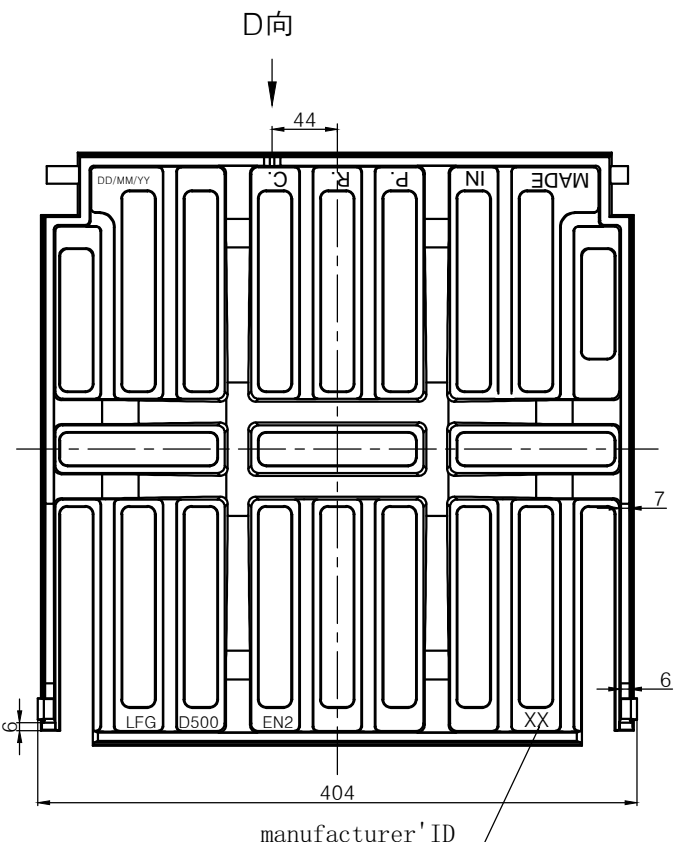
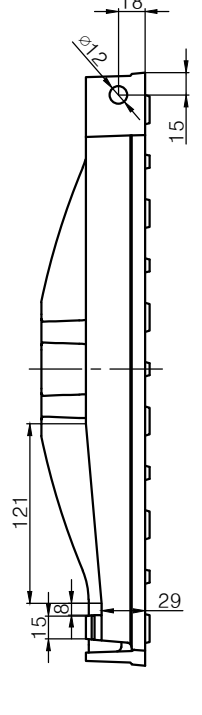
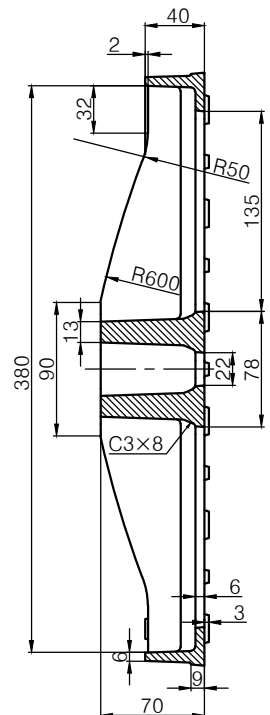
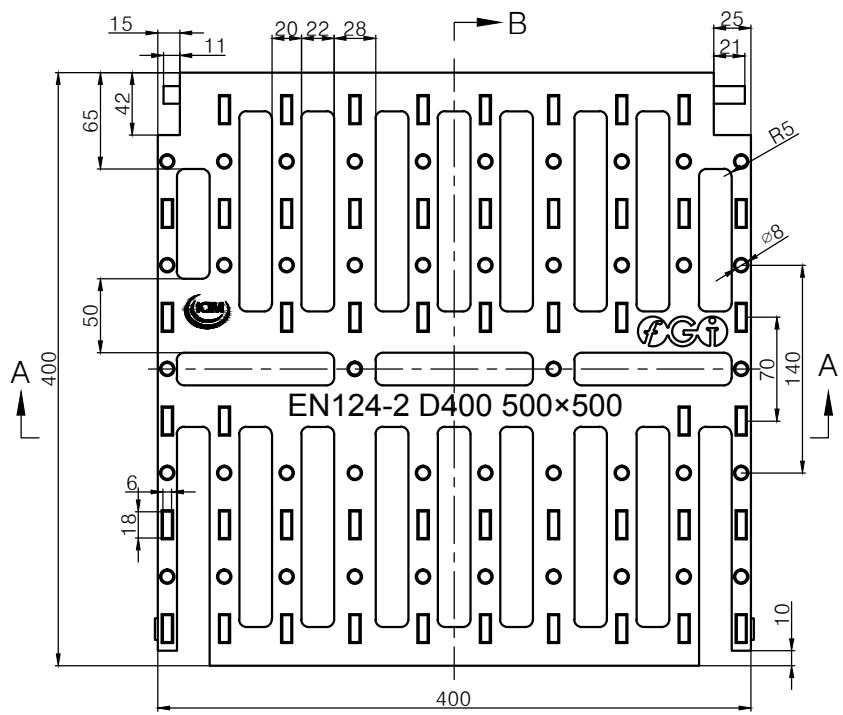

MATERIAL	GJS500-7	WEIGHT	17kg	CLASS	EN124-2 D400	SCALE	MARK:
						SIZE	CERTIFICATE NO. / PRODUCT CODE
						500×500×80	ICIM
						NAME	L-GSGEN-450FL
						ITEM CODE	
						EDITION	SHEET
						0	3/3

