

Technical requirement

- 1, pattern draft is 1-2° of main beams ,cover ,grids, frame side.
- 2, pattern draft is 5-10° of assistive beams ,gird holes ,outside.
- 3, pattern draft is 15° of surface patterns ,mark, logo.
- 4, casting radius which aren' t been marked is R1-R3.

General Dimension Tolerance	General Weight Tolerance
According To ISO 8062-CT10	Tolerance(%)
	±5%

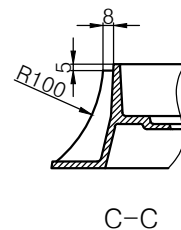
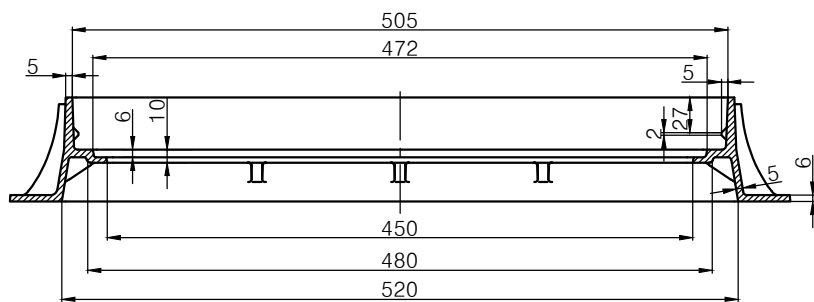
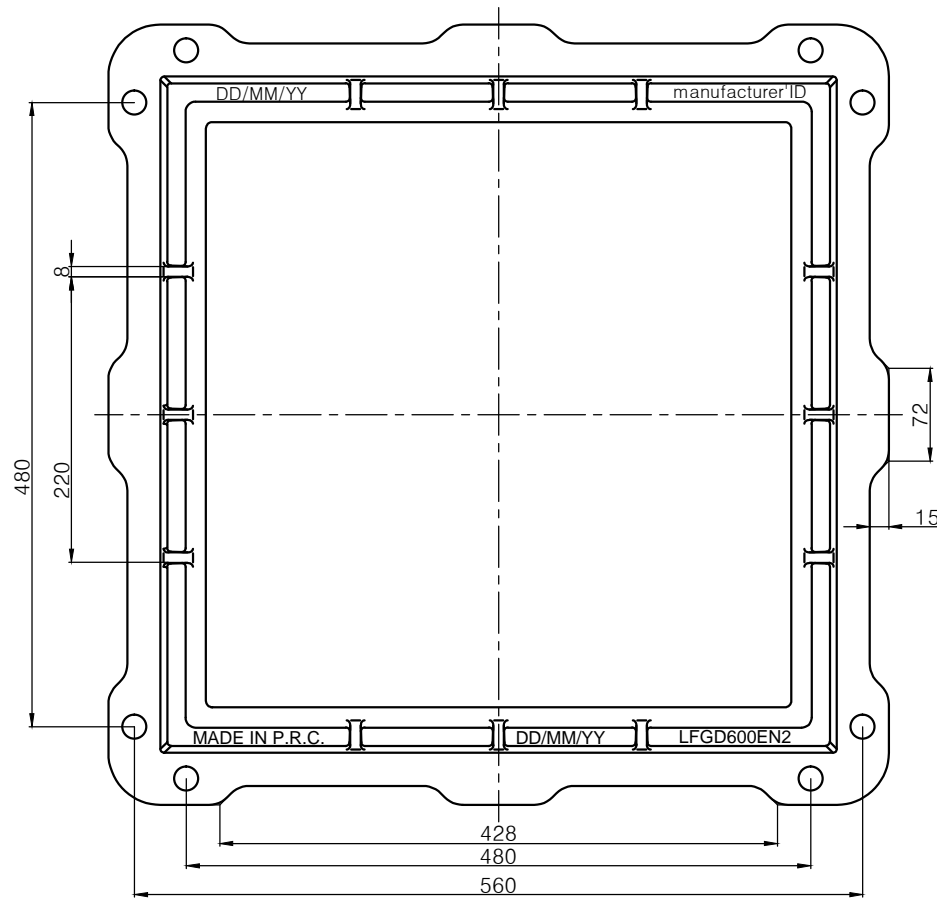
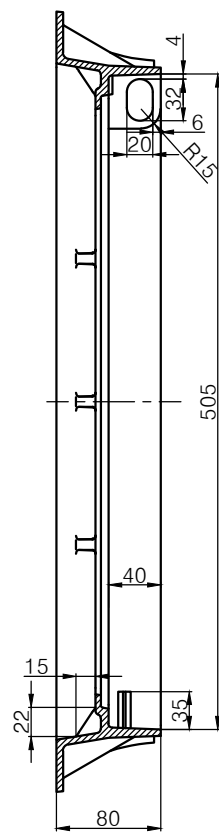
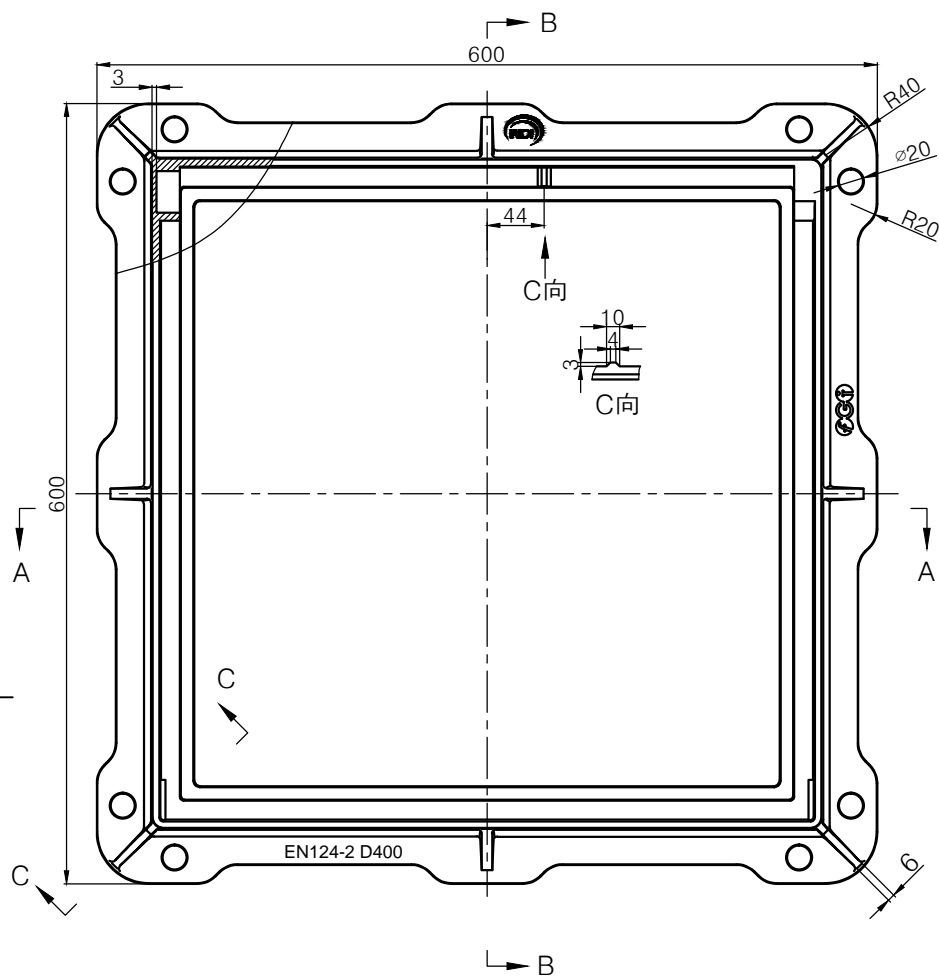

MATERIAL	GJS500-7	WEIGHT	36kg	CLASS	EN124-2 D400	SCALE	MARK:		
						SIZE	CERTIFICATE NO. /	ICIM	
						600x600x80	PRODUCT CODE		
						NAME	L-GSGEN-460FL		
						ITEM CODE			
 OBLIKUJEMO VODNE CESTE						EDITION	SHEET		
						0	1/3		



A-A

B-B

C-C

MATERIAL	GJS500-7	WEIGHT	11.5kg	CLASS	EN124-2 D400	SCALE		MARK:	
						SIZE	600×600×80	CERTIFICATE NO. / PRODUCT CODE	ICIM
						NAME	L-GSGEN-460FL		
							ITEM CODE		
								EDITION	0
								SHEET	2/3

